

HSC Medical Center, Malaysia

Malaysia's Leading Healthcare Provider Relies On Allied Telesis' Network Solutions To Drive Customer-Centric Services



THE CUSTOMER

HSC Medical Center (HSC) was officially opened on 18 February 2003 with the aim to bring a new approach to healthcare services. It focuses on niche areas such as preventive diagnostics, early detection and treatment of life threatening diseases. HSC believes in providing an all encompassing integrated healthcare services under one roof. It provides advanced medical and cardiac therapeutic services and is fully equipped with endoscopy, heart treatment, cardiac care, O&G, fertility, traditional Chinese medicine, and acupuncture facilities to give the best treatment option for its patients. It is one of the few centers in the world that have the most advanced & comprehensive health screening packages for heart disease, stroke and cancer patients that are reasonably priced.

HSC is committed in providing quality and professional healthcare solutions or services to its patients and their families by maintaining a pool of well-trained and highly-experienced physicians and other medical personnel who are skilled in utilizing some of the latest technology and procedures in cardiovascular science.

HSC constantly improves its facilities by expanding and upgrading its human and technological resources to meet the increasing demand for its services. The center is now fully equipped with an integrated computerized system and state-of-the-art diagnostic and therapeutic tools.

THE CHALLENGE

Situation Analysis

Given the scale and the increased demand of quality health services, HSC established their second medical center within the Klang Valley to provide a wider range of healthcare services to their customers. The expansion resulted in increased bandwidth well beyond its current network capabilities at both the Kuala Lumpur and Cheras centers. As such, the hospital requires a highly reliable, well-integrated, and cost-effective network infrastructure system to achieve the following:

- Allow doctors to share and access medical information on patients

- Enable seamless flow of information, transfers of big imaging files as well as medical data between the centers
- Ensure timely decision making which is critical in providing quality healthcare services
- Leverage medical experts and resources across both centers
- Enhance customer retention by delivering additional value added services
- Consolidate services over one simplified access network

“Maintaining the quality and clarity of those imaging files are crucial because doctors have to be precise when diagnosing diseases,” said Dr. Soo Chee Siong, Medical Director, HSC Medical Center

Moreover, the transfer of quality images can quicken the diagnostic process which can be a matter of life and death to a patient – as early detection and treatment can save lives.

HSC according to Dr. Soo, is a customer –centric healthcare provider. As such the medical center must constantly strive to provide faster response time to its patients. This requires a reliable IT infrastructure which is supported by a reputable vendor.

Challenges and Issues

In the medical field, time is of essence. Hence, HSC’s greatest challenge is to find the fastest way to share its resources and experts to ensure they can get back to their patients within the shortest time possible. With the two centers located apart, it is of vital importance to provide quicker diagnostic results to patients.

Sending big imaging files to another center electronically over a broadband connection is definitely faster compare to the traditional way via courier or mail which are time consuming, cumbersome and costly.

In addition, HSC planned to streamline its operational workflow to ensure all important data reside in a central location that is easily accessible by all its medical experts.



Selection Criteria

While price/performance, good customer support and an open and direct communication with its vendor are important selection criteria, HSC placed priority on selecting a vendor who understands the nature of its business and services. HSC was looking for a vendor that has experience in providing reliable Telemedicine network infrastructures.

After a thorough selection process, HSC chose Allied Telesis, one of the leading global IP networking leaders. With a solid track record of supporting the Asia Pacific Advanced Network (APAN) Telemedicine initiative with Virtual Private Network (VPN) and high speed switching technologies, Allied Telesis met and exceeded HSC's requirements.

"Allied Telesis offers the experience, knowledge and technology that we were looking for. Its solutions are able to seamlessly integrate our new and existing network. This resulted in giving HSC the best Total Cost of Ownership (TCO). I'm happy that Allied Telesis meet all the stringent requirements within the hospital's budget," said Dr. Soo.

The Solution

Allied Telesis presented a flexible, cost-effective switching and routing solution that could grow with HSC. The solution was adopted using the Allied Telesis AR750S series routers, AT-9724TS and AT-9748TS series Stackable Layer 3 Switches. The AT-AR750S router provides IPsec VPN connectivity from HSC Darby Park, Kuala Lumpur to HSC PGRM, Cheras (remote site) over Broadband xDSL services. The Allied Telesis routers and switches both supports SSH, which allows secure, encrypted, remote management and configuration of the hardware.

In HSC Darby Park, the AT-9724TS and AT-9748TS switches provide the workstations and servers with 10/100/1000Mbps

LAN connectivity. The network supports multiple VLANs namely iCare and Siemens. Layer 3 Routing enabled the switches to facilitate connectivity between the two VLANs. On the HSC remote site (PGRM), the AT-9724TS is installed to provide LAN connectivity 10/100/1000Mbps to all the workstations and servers. Similarly, the PGRM network supports multiple VLANs.

There are two IPsec VPN tunnels created via two separate xDSL lines, supporting iCare and Siemens applications respectively. The Siemens application is delay sensitive, and is a mission-critical application.

The Result

The investment in Allied Telesis's solution proved worthwhile. The benefits of the new solution were immediately felt.

With a secure high-speed broadband network between the centers, HSC experienced increased coverage that allows the various resources and facilities to be shared across the network. The LAN implementation, meanwhile, allows users the convergence of voice, video, and data. Medical specialists, surgeons, doctors, nurses, and allied medical hospitals and professionals are all assured of full access to network resources. They are able to utilize the network to share information efficiently and effectively. For example, graphical content can be referred directly from examination rooms, and clinical laboratory center examination outcomes can be easily checked on a real-time basis.

"Allied Telesis prides itself in helping customers enhance its competitiveness and efficiency. To be able to contribute to HSC's customer-centric vision is what we strive to achieve," said Paul Choy, Country Manager, Malaysia, Allied Telesis.

Case Study | HSC Medical Center, Malaysia

“HSC is extremely satisfied and we are impressed with the quality and performance of Allied Telesis products. The credit goes to Allied Telesis’ team who has the in-depth knowledge and expertise. They have shown great care and concern of our challenges,” Dr. Soo remarked.

“The new network allows HSC to gain competitive advantage and stay in the forefront of our profession and keeps us abreast of technological advances. We certainly look forward to working with Allied Telesis again when the next opportunity comes,” concluded Dr. Soo.

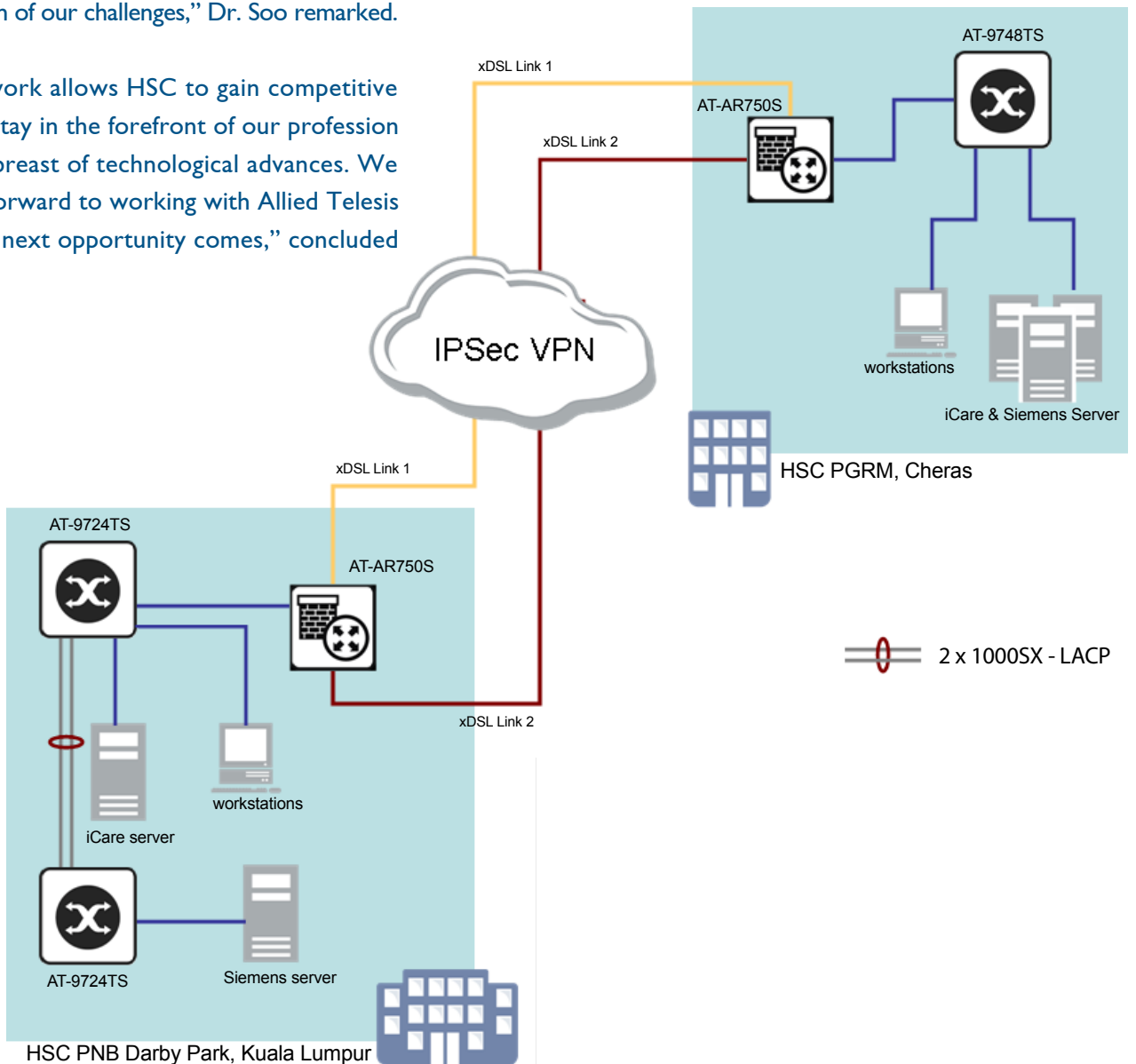



Featured Products

AT-AR750S

10/100T x 2 WAN ports secure modular VPN router with LAN 10/100T x 5 ports, 2x PIC slots, 1x Async console

The AT-AR750S is a very high performance firewall and VPN concentrator offering up to 192Mbps of IPSEC throughput. Dual Ethernet WAN ports and two Port Interface Card (PIC) bays create a very flexible WAN router. The Stateful Inspection Firewall makes the AR750S suitable for secure routing applications.



AT-9748TS/XP

10/100/1000 x 48 ports Gigabit Ethernet Layer 3 switch with 4 combo SFP expansion bays, 2 20Gbps stacking ports and 1 expansion slot for dual 10 Gigabit XFP connectivity

An entry level Layer 3 Gigabit Ethernet switch. This stackable switch features dedicated stacking interfaces with 40Gbps of stacking bandwidth. It offers two dedicated stacking interfaces for a resilient ring stack topology and can support two 10Gbps XFPs.



AT-9724TS

10/100/1000 x 24 ports Gigabit Ethernet Layer 3 switch with 4 combo SFP expansion bays and 2 20Gbps stacking ports

Advanced Layer 3 switch, with IP routing capabilities for investment protection and flexible management and the ability to expand as network demands grow. Provides Layer 3 functionality to support converged services like voice and video, which are becoming more and more integrated into data networks.



Allied Telesis

Allied Telesis was founded in 1987, a global provider of secure Ethernet/IP access solutions and an industry leader in the deployment of IP Triple Play networks over copper and fiber access infrastructure. The attributes which have led Allied Telesis to achieve its leading position in the enterprise, operator and connectivity business segments can be summarised by four key elements: its business focus on networking technology for professional markets, where Allied Telesis has proved to be the only company capable of providing a total end-to-end solution at a high price/performance ratio; the ability to handle every aspect of its own products from design to marketing; the development of components and solutions which accommodate flexible, efficient and reliable network construction; and support from sound warranty terms and quality services. Allied Telesis connects the IP world efficiently thanks to affordable and highly reliable network solutions.